

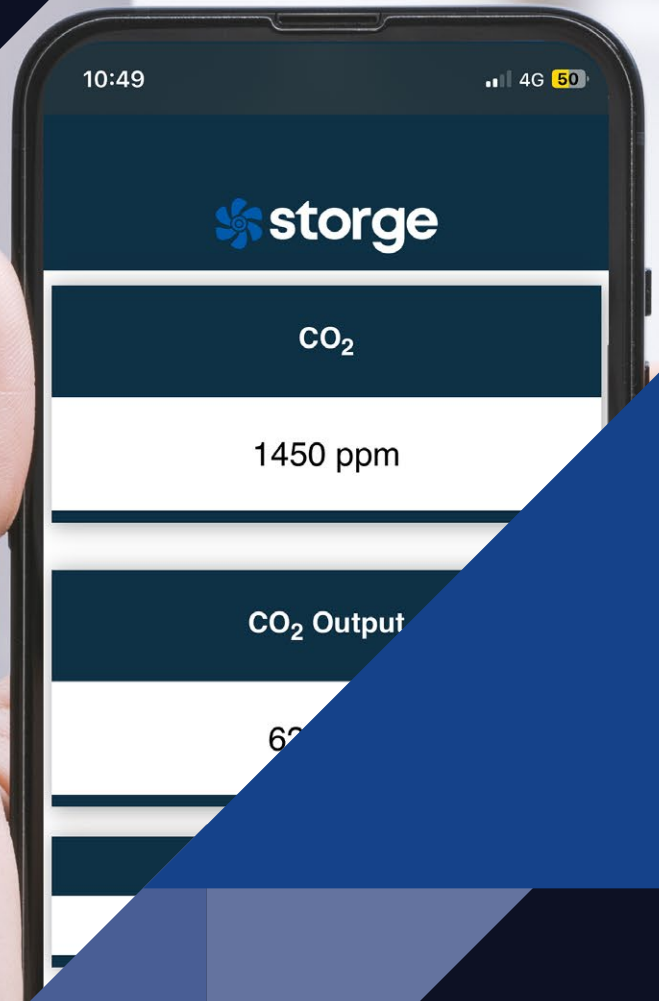

STORGE | STG-01 CO₂ CONTROLLER
APRIL_2024_V0.4



—
STG01 - CO₂
CONTROLLER
—

CONTROLLER STG01 - CO₂

The STG Controllers are an easy way to automate ventilation systems and promote thermal comfort and air quality for your business.

The products feature temperature, humidity, carbon monoxide, carbon dioxide, volatile organic Compounds and fine particulate matter sensors, with the possibility of customization according to the project and software personalization for your application.

They are precise in variable control, easy to install, and can be easily accessed through their WI-FI interface, or the STG-IHM Touch Screen, offering both analog (0-10V) and digital outputs for each parameter.

SPECIFICATIONS STG01 - CO₂

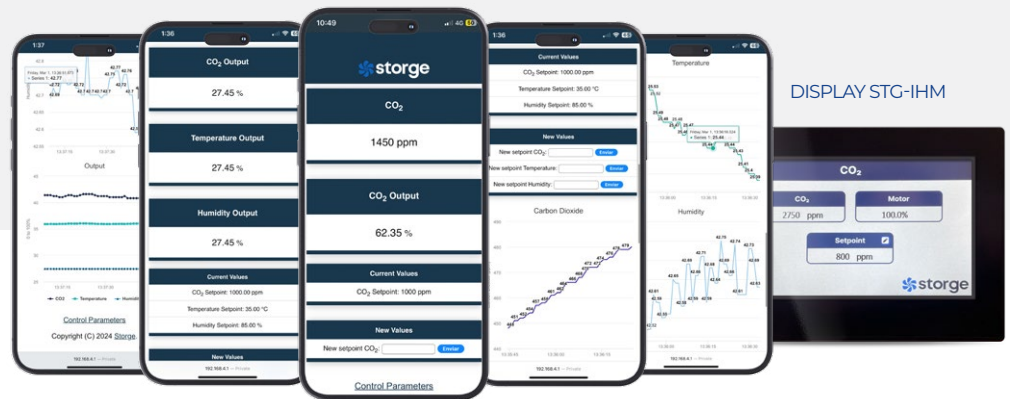
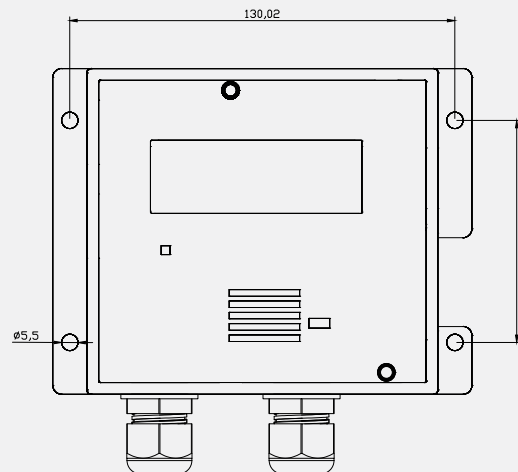

EXPLORE OTHER AVAILABLE PARAMETERS AND CUSTOMIZATION POSSIBILITIES.

SOLD SEPARATELY. COMPATIBLE WITH ALL STG CONTROLLERS.

DESCRIPTION

CORRESPONDENCE

MODEL	STG01 - CO₂
MONITORED VARIABLE(S)	CARBON DIOXIDE
MEASUREMENT RANGE	400 ~ 8192 PPM
POWER SUPPLY VOLTAGE	24 VDC
POWER SUPPLY TYPE	WALL CHARGER (P4 JACK CONNECTOR) OR SWITCHED POWER SUPPLY (CONNECTION VIA 1.5 MM ² CABLES)
01 ANALOG OUTPUT	0 ~ 10 VDC
RELAY OUTPUT	NO + NC
CURRENT SUPPORTED BY THE RELAY	10 A (120 Vac) OR 7 A (240 Vac)
WEB INTERFACE FROM OWN WIFI ACCESS POINT	YES
WIRELESS COMMUNICATION WITH OTHER STG UNITS	YES (CUSTOMIZATION OPTION)
STORAGE TEMPERATURE	6 A 40° C



STORGE

477 MARIALVA STREET – BLOCK 12, LOT 13A1, EMILIANO PERNETA, 83324-197, PINHAIS – PR – +55 41 3056-3431
STORGEENGENHARIA.COM.BR